

⚠ Must read before use. Failure to do so can result in serious injury or death.

Vor Gebrauch unbedingt lesen. Andernfalls sind schwere Verletzungen oder Todesfälle möglich. **HIER SCANNEN.**

À lire absolument avant toute utilisation. Le non-respect de cette consigne peut entraîner des blessures graves, voire mortelles. **SCANNER ICI.**

Leer antes de usar. El no hacerlo puede resultar en lesiones graves o muerte. **ESCANEE AQUÍ.**

Lezen voor gebruik. Het nalaten hiervan kan leiden tot serieuze verwondingen of de dood. **SCAN HIER.**

Da leggere prima dell'uso. In caso contrario, possono verificarsi lesioni gravi o morte. **SCANSIONA QUI.**



SCAN HERE



Pizza Oven Instruction Manual

IMPORTANT SAFETY WARNINGS

KEEP THESE INSTRUCTIONS FOR FUTURE USE. DO NOT DISPOSE OF THIS MANUAL. Read instructions in full prior to assembling and using the Pizza Oven. Failure to comply with all provisions and usage guidelines could result in property damage, serious bodily injury, death, or fire.

	WARNING! FOR OUTDOOR USE ONLY!
Carbon Monoxide is a colorless, odorless gas that can kill. It is released during the combustion process of organic fuels and normally dissipates in open air, outdoor environments. Do NOT use the Pizza Oven inside a structure, tent, vehicle, under covered patios, awnings, near open windows, in close proximity to indoor areas, or in tightly fenced spaces that may concentrate this gas and lead to Carbon Monoxide poisoning.	

- Do NOT use this appliance within 10 feet of combustible materials. Do NOT store any flammable liquids or pressurized gas tanks not directly connected to the Pizza Oven within 25 feet of this product.
- WARNING: Pizza Oven surfaces may be hot. Do not touch exterior surfaces while in use. Use heat resistant gloves when using the Pizza Oven. KEEP AWAY FROM CHILDREN AND PETS. Never leave the Oven unattended while in use or until the Pizza Oven has completely cooled.
- Do NOT use on plastic tables or portable tables that are not designed to accommodate cooking appliances.
- Do NOT use on tables with coverings of any kind, including plastic and fabric tablecloths.
- Use ONLY on a level, stable, heat resistant surface.
- Do NOT move the Pizza Oven while in use.
- Do NOT use on boats, floating docks, or recreational vehicles.
- Use only kiln-dried hardwoods fuels.
- Do NOT use other fuels or fuels with additives.

- Do NOT use wood pellets.
- Do NOT overfill fuel grate or attempt to remove ash pan or fuel grate while in use.
- Do NOT use chemicals or accelerants to light. Use only natural food safe paraffin-based fire starters.
- Rear door will be hot during use. Do NOT set doors on surfaces that can be damaged by heat.
- Always use detachable handle to lift and move doors.
- Do NOT burn wood in the Pizza Oven and attempt to use the Pizza Oven Gas Burner at the same time. Serious Bodily Injury or Property Damage could result.
- If using the Pizza Oven Gas Burner, the ash pan and fuel grate area must be completely cool and cleaned of any ashes prior to installing and using the Gas Burner.
- Do NOT cover the Pizza Oven until the Pizza Oven has completely cooled and all ashes have been properly cleaned out and disposed of.
- Do not use at night without sufficient lighting surrounding the Pizza Oven. Inspect surrounding areas for potential trip hazards. Do NOT use electrical cords near the Pizza Oven.
- Inspect your Pizza Oven before every use. Altered, damaged, or missing parts may cause bodily injury or property damage.

	WARNING! FIRE HAZARD!
DISPOSE OF ASHES PROPERLY! Ashes should be placed into a metal container with a sealed metal lid. Ashes and embers can maintain heat and combustion even after several hours. Handle with care.	
<ul style="list-style-type: none"> • Do NOT dump ashes within 25 feet of combustible materials, into plastic garbage bags or into any combustible containers. • Do NOT store ashes in any enclosed area • Do NOT dump or move ashes in windy conditions • Do NOT attempt to remove the Ash Pan or Ash Pan Grate while the oven is in use or until ashes have cooled completely. • Review all local ordinances, outdoor fire guidelines, and burn ban notices prior to using the Pizza Oven. 	

	WARNING! SURFACES WILL BE HOT!
Use caution when operating the Pizza Oven. Outer surfaces will be HOT and should NOT be touched.	
<ul style="list-style-type: none"> • Use heat resistant gloves at all times and use detachable handles when lifting and removing. • Flames can occasionally reach outside of the Pizza Oven's front opening, rear door, and lower rear air inlets. Follow all spacing and placement guidelines in these instructions and keep children and pets away. DO NOT LEAVE THE PIZZA OVEN UNATTENDED. • Keep hands and face away from pizza oven openings. Interior air and surface can reach 250-500°C • Do not use the Pizza Oven as a heater 	

When operated in a safe and responsible manner your Solo Stove Pi Pizza Oven will provide years of enjoyment and oven fresh pizza for your family and friends. Ensure these instructions are read often and understood by all individuals using the Pizza Oven.

BEFORE YOU BEGIN





Scan for easy 3D instructions
Download the BILT app before you begin

INCLUDED PARTS

When removing items from the box, take extra care to unwrap each component and inspect them for damage.

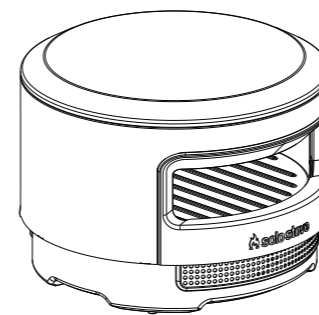

Pizza Oven Body

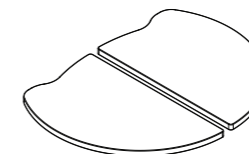

Pizza Stone (2 Halves)

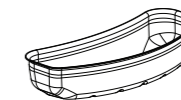

Fuel Grate

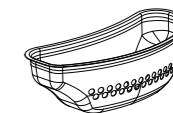

Ash Pan

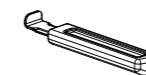

Rear Door Handle

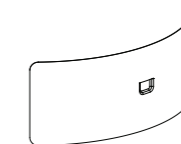

Rear Door

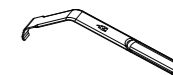

Fuel Stoker

ASSEMBLY

Before assembly, remove all items from the box, carefully unwrap, and inspect for damage.

Wood-Firing

01 - Place Pi on a Safe, Sturdy Surface

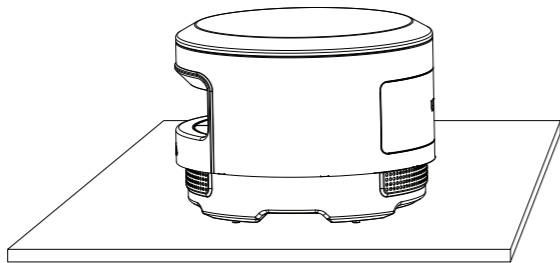

02 - Install Pizza Stone Halves

Insert one pizza stone half through the front opening of the oven body, matching the orientation shown below. Once inside the oven, move the pizza stone half completely to the side to give room for the second half. Each pizza stone half should lay flat on the metal support tray and will not rest on top of each other when installed correctly.

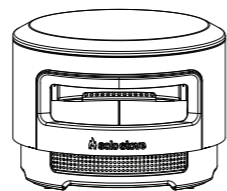
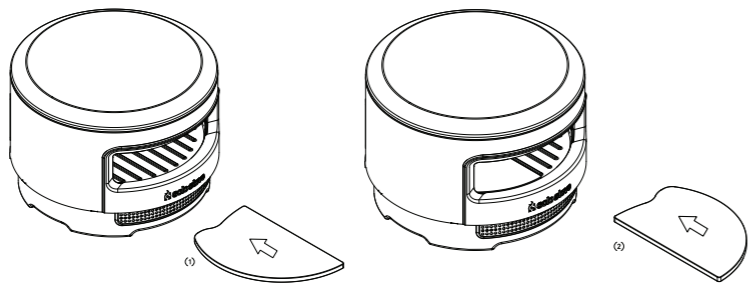

Stone halves installed correctly

03 - Install Ash Pan and Fuel Grate

First, insert the fuel grate into the ash pan. When the fuel grate is completely nested inside the ash pan, place the entire unit inside the rear opening of the oven body as shown.

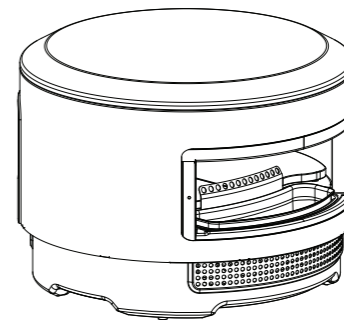
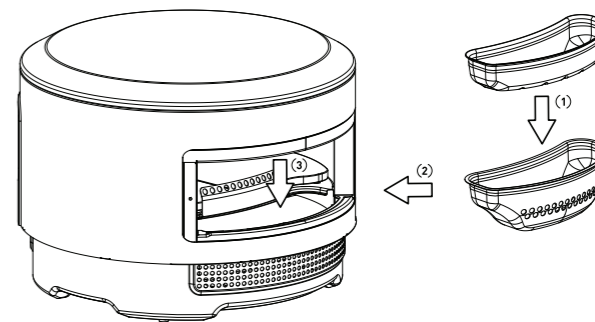

When installed correctly the ash pan and fuel grate will align, and will not stick up above the lower door jamb.

04 - Rear Door

The rear door can be quickly placed or removed using the detachable handle.

To install the rear door, attach the handle and lower the door into the rear opening at a slight angle until the edges of the door are flush with the oven body.

CAUTION! Always inspect the rear door after installation to ensure it rests **flush** with the outside of the oven body. If the door is damaged or does not rest flush, **do not use** the Pizza Oven. Serious injury or risk of exposure to flame could occur while operating a damaged Pi Pizza Oven.

Contact Solo Stove Customer Support for assistance.

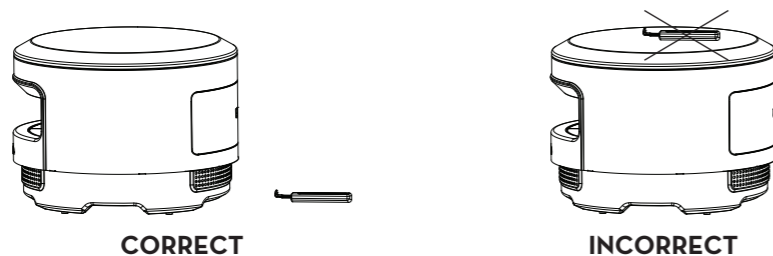
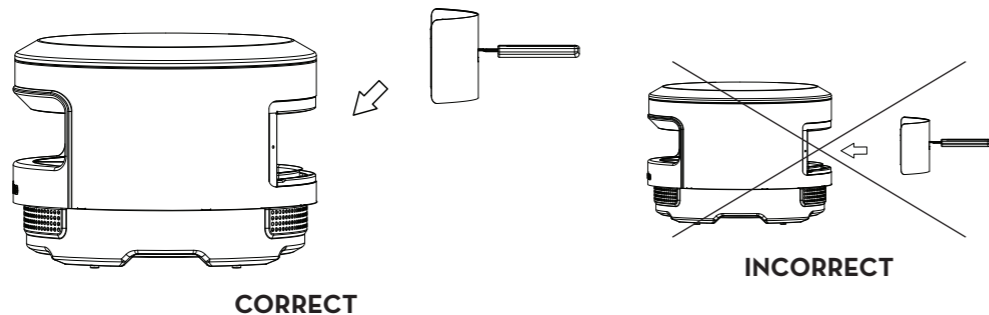

The rear door handle is designed to be used only when moving the door and will not stay in the door handle recess when let go. The rear door should remain closed as much as possible during use to minimize heat loss. Store the rear door in a safe place in between uses.

DO NOT set or store the handle directly on top of the oven, unless using the Pi Silicone Mat.

LIGHTING & OPERATING INSTRUCTIONS

Lighting

01 - Access The Fuel Grate

Remove the rear door to access the fuel grate.

Place 2-3 natural fire starters in even spacing at the bottom of the fuel grate, then light the starters.

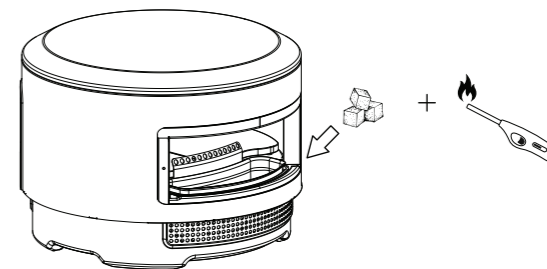

02 - Add Wood

Place 4-6 pieces of kiln-dried wood on top of the starters and allow them to catch fire.

For best results, wood pieces should be approximately 4-5 inches long with 1-1.5 inches in diameter. Smaller pieces will burn too quickly, while larger pieces will smoke and take longer to catch fire.

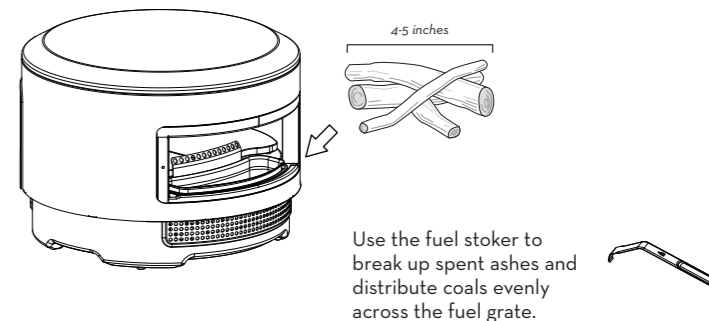

03 - Preheat

Once the fire is sustained, replace the rear door. Let the oven preheat for 15 minutes, or until the pizza stone reaches approximately 650°F. Use an infrared thermometer to measure the very center of the pizza stone.

Keep your Pi at optimum temperatures by adding 1-2 pieces of wood every 5 minutes. Temperature and refueling intervals may vary depending on the size of your wood.

Start with adding the minimum amount and increase as needed.

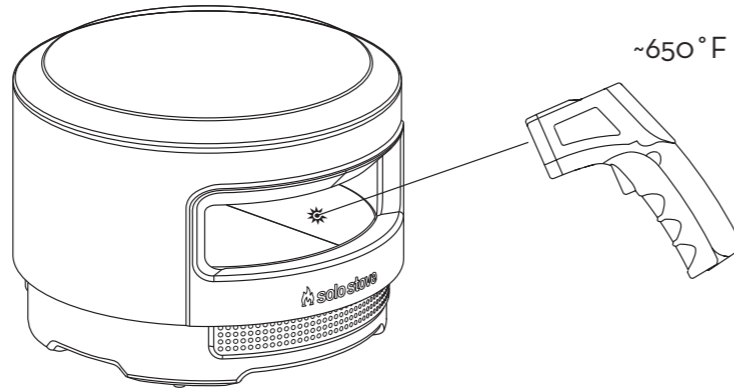

General Use

For every use, inspect the four rubber feet on the bottom of the oven. If any are missing or damaged, **do not use the Pizza Oven**. Contact Solo Stove for replacement parts.

With normal use, the ash pan will allow for up to 2-3 hours of use before it becomes full. The Pizza Oven must cool completely before a full ash pan can be emptied.

- **Dispose of ashes responsibly**, preferably into a metal can. Ashes and embers can maintain heat and flammability even after several hours.
- **Do not** dump ashes within 25 feet of combustible materials, into plastic garbage bags, or into any combustible containers.
- **Do not** empty ashes in windy conditions.
- **Do not** attempt to remove the fuel grate or ash pan while the Pizza Oven is in use.

Rear door may be hot when in use. Use only the detachable handle to remove and install the door.

- Rear door should be set in an upright position when removed from the oven and when not in use.
- Only set the rear door on surfaces that are heat tolerant. Do NOT set on plastic surfaces.
- Do NOT set doors on the ground, near children or pets, or where they would be susceptible to damage.
- Handle rear door with care. Hard impacts can damage or bend the door which will affect how it functions. Damaged doors should not be used. Contact Solo Stove for replacement parts.

CARE

Pizza Oven Body

Discoloration

Cooking with wood will produce varying amounts of smoke. This smoke will cause some discoloration above the front opening. The dark residue that forms on the surface is normal and can be cleaned **once the Pizza Oven has cooled.**

The oven body is 304 stainless steel, a strong and corrosion-resistant steel that will slowly discolor and patina over time. This is normal and should not be construed as a defect. This process is accelerated by heat, which is why different areas of the Pizza Oven will patina or discolor differently than others. This discoloration is both on and in the surface of the steel, and it is not something that can be completely cleaned off.

Cleaning

Dirt, residue, and debris can be cleaned off using warm soapy water applied to a clean, lint-free towel. Never spray cleaning solutions directly on the Pizza Oven. Dampen the towel first, then clean in the direction of the brushed grain.

- **Do not** use abrasive cleaners or scouring pads to clean the oven body, as these could scratch the stainless steel surface.

The oven interior can be cleaned in the same way you would run a self-cleaning cycle of a standard oven. Fire it up on high heat to burn off any crumbs or residue. Once the oven has completely cooled, brush away the debris. You can also wipe down the metal surfaces with a damp cloth.

Care

- **Do not** drop the oven or place items directly on top of the oven, unless using the Pi Silicone Mat.
- **Do not** store items inside the oven.

Pizza Stone Halves

Discoloration

The pizza stone is made from Cordierite, a porous material commonly used for cooking stones. This type of material will age the more it is used and will naturally discolor in areas over time.

Cooking

When cooking, a light amount of semolina, cornmeal, or flour can be used to help prevent food from sticking. Loose cornmeal will burn off over time and can be brushed to the sides in between cooking and removed when the Pizza Oven has cooled.

The pizza stone halves are reversible, and each side will last up to 1-3 years with normal use. Over time, the pores of the pizza stone will accumulate food residue, which will affect how the food tastes and how well the stone transfers heat to foods.

Use genuine Solo Stove replacement stones when needed.

- **Do NOT** place frozen or extremely cold foods on the pizza stone.
- **Do NOT** drop the pizza stone. Breakage may occur.
- **Do NOT** use a damaged or chipped pizza stone.

Cleaning

Do not attempt to clean the pizza stone while it is still hot. Allow it to cool before conducting any routine cleanings.

Occasionally remove and brush off the pizza stone. Burnt on materials should be removed with a stiff nylon brush or plastic scraper.

In extreme cases, medium grit (100-120) sandpaper can be used to remove stubborn surface deposits. Then, wipe down with a clean, lightly damp cloth.

- **Do NOT** use metal scrapers as they may damage the stone.
- **Do NOT** use soap or chemicals on the pizza stone or submerge it in water. The pizza stone will absorb these which will affect how your food tastes. Prevent excessive moisture from contacting the stone as it may cause the stone to crack when heated.

Grease Fires

Do not put fatty foods or oils directly onto the pizza stone. Fatty foods or oils will create build-up and could cause unpleasant smells, excessive smoke, or lead to a grease fire.

If a fire does occur, carefully remove all foods from the Pizza Oven and allow flames to subside. Call the Fire Department if the flames do not extinguish within 15 seconds or are reaching outside of the oven openings.

- **Do NOT** use water to put out fires caused by fatty foods or oils as it may cause the fire to spread.

Solo Stove does not accept any responsibility, legal or otherwise, for the incidental or consequential damage to property or persons resulting from the misuse of this product. Solo Stove shall in no event be liable for any special, indirect, consequential, or other damages of any nature whatsoever in excess of the original purchase price.



 solo stove®

v1.0